

NATIONAL CALL TO INDIGENOUS ARTISTS

PUBLIC ART OPPORTUNITY FOR
ROYAL AVIATION MUSEUM OF WESTERN CANADA (RAMWC)

THE PROJECT

In early 2022, Royal Aviation Museum of Western Canada (RAMWC) will reopen in a new location near the Winnipeg James Armstrong Richardson International Airport.

As the museum seeks to honour and commemorate Indigenous Peoples' history and aviation in Western and Northern Canada, we share stories of Indigenous involvement in aviation across Northern Canada throughout the exhibits covering two floors of display space.

To commemorate this new space and the museum's renewed relationship with Indigenous communities, the museum invites Indigenous – First Nations, Métis, and Inuit – visual artists residing in Canada to submit expressions of interest and qualifications to work with the curatorial staff at RAMWC to create one (1) public artwork installation in the new museum's welcoming gallery.

This artwork commission will pay CAD\$25,000* to the successful applicant.

RAMWC BACKGROUND

RAMWC was established in Winnipeg more than 40 years ago by a small group of visionaries committed to preserving Canada's distinct aviation heritage. The museum remains one of Canada's largest and most complete aviation heritage collections. We are one of only six "Royal" museums in Canada, recognizing the hard work of our team and the partnerships we hold to help preserve the legends that aided in shaping the nation that we know today.

Royal Aviation Museum of Western Canada is located on Treaty 1 territory, the traditional territory of Anishnaabeg, Cree, Oji-Cree, Dakota, Lakota, and Dene Peoples, and the homeland of the Métis Nation. We respect the Treaties that were made on these territories, we acknowledge the harms and mistakes of the past, and we dedicate ourselves to move forward in partnership with Indigenous communities in a spirit of reconciliation and collaboration.

* The museum will cover certain expenses over and above the commission payment – to be communicated.



**ROYAL
AVIATION MUSEUM**
OF WESTERN CANADA



RoyalAviationMuseum.com

ARTWORK LOCATION

The commissioned artwork will be front and centre on a “Welcome Column” as guests enter the museum. The artwork’s space is highlighted in orange in the rendering to the right.

Given its prominence at the entry point of the Richardson Gallery of Flight, this piece may be used in tours, marketing, and branding of the museum, so it should reflect and embody the spirit and intention of the work and relationships within the history and future of aviation in Western and Northern Canada.

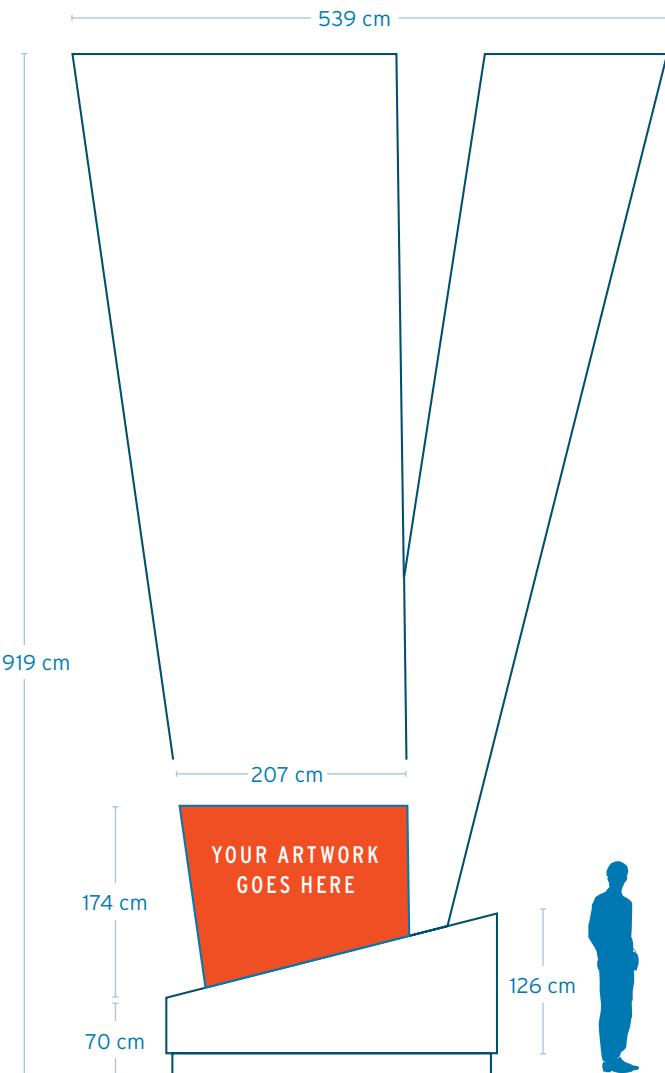

ARTWORK THEMATIC

This public art project calls on the artist to engage the histories, legacies, and impacts of aviation between Indigenous and non-Indigenous communities in Western and Northern Canada. It seeks to draw upon the rich Indigenous cultures, peoples, and heritage while also drawing upon how aviation entered Indigenous networks, helped build and challenge relationships, and introduced aspects of Canadian society.

ARTWORK DIMENSIONS

The commissioned artwork will need to fit on an irregularly shaped space. The artwork could be rectangular; however, its aesthetic and meaning will need to be maintained with these small areas cropped out.

We share stories of Indigenous involvement in aviation across Western and Northern Canada.



**ROYAL
AVIATION MUSEUM**
OF WESTERN CANADA

RoyalAviationMuseum.com

ARTWORK FORMAT OPTIONS

OPTION #1

The commissioned artwork is a digital piece to be incorporated into the banner graphics, either in the full polygon shape provided or as a cropped portion of the shape as defined by the artist.

OPTION #2

The commissioned artwork is a physical 2D piece which will be photographed and then incorporated as a graphic as part of the welcome banner, either in the full polygon shape provided or as a cropped portion of the shape as defined by the artist.

If the commissioned piece is a physical 2D artwork, the original piece will be displayed separately at the new museum.

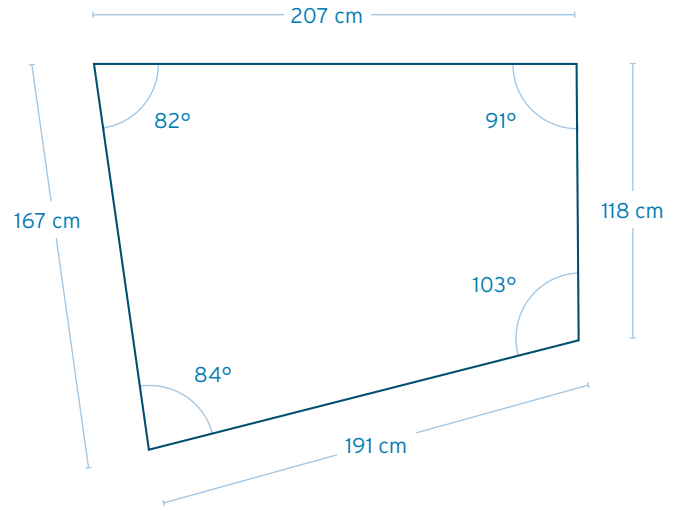

ARTWORK CROPPING #1

 Light blue area represents visible portion of rectangular artwork of the shown size.

 Orange dashed line represents rectangular artwork before cropping.

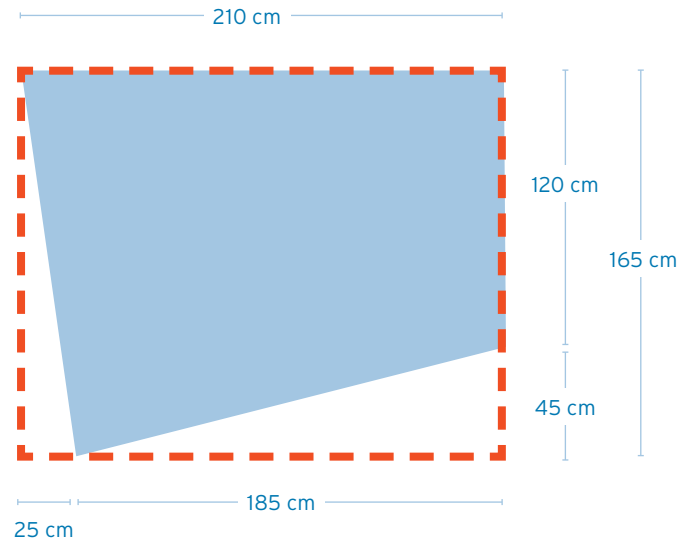

ARTWORK CROPPING #2

 Light blue area represents visible portion of rectangular artwork of the shown size.

 Orange dashed line represents rectangular artwork before cropping.

 Bottom portion to be continuation of graphic at top segment of banner.

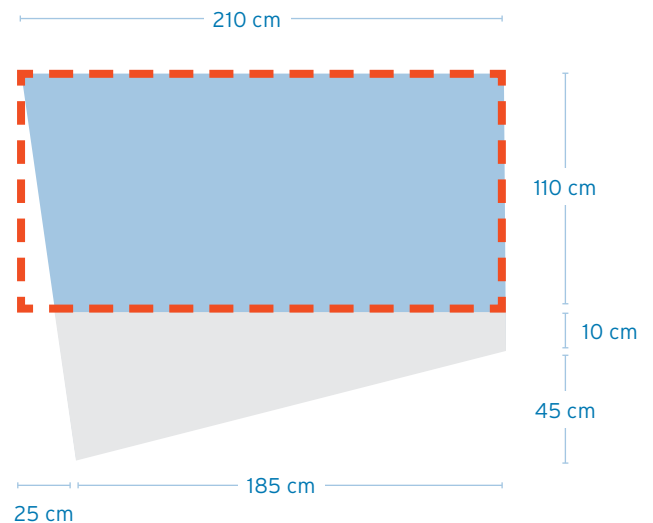



HOW TO APPLY THE PROPOSAL PACKAGE

Artists wishing to be considered must submit a complete proposal package. All supporting materials must accompany the application.

Artist applications will be reviewed based on artistic excellence. Experience with community engagement and a desire to create artwork for and in the public realm is also required.

For a proposal to be considered complete, **it must include all** of the following items:

1. Artist Information and biography, including Indigenous community affiliation.
2. Written Expression of Interest (Maximum 1 page) - Please include your interest in aviation and Indigenous communities and how your work can contribute to this complex history. Please also highlight your qualifications and experience working with site-specific artwork and construction and design professionals, as well as your ability to successfully execute a project of this scale on time and within a budget.
3. Curriculum Vitae, including a brief statement of artistic activities
4. Two references who can speak to your art practice, including their name, address, phone, and email. Letters of reference are not required at this time.
5. Published support material, including any links or copies of published materials such as critical writing about your work or media clippings. You may also provide digital images representative of your previous work for the selection committee to review.

DEADLINE

Complete proposal packages must be received on or before October 15, 2021. Please send completed application packages to:

ELECTRONICALLY:

Davide.Montebruno@royalaviationmuseum.com

MAIL/COURIER:

Royal Aviation Museum of Western Canada
Indigenous Artwork Commission
1431 Church Avenue
Winnipeg, Manitoba
R2X 1G5
ATTENTION: Davide Montebruno

Note: A finished piece of artwork will only be required if your proposal is successful.



**ROYAL
AVIATION MUSEUM**
OF WESTERN CANADA

RoyalAviationMuseum.com